

TEAM DURANGO DEX410 SETUP SHEET

PRINT

SUBMIT

NAME / NOM: Adam Skelding

DATE / DATUM: 27/06/2010

SETUP BLATT / FICHE DE RÉGLAGE V1.3 E

EVENT / VERANSTALTUNG: BRCA National Round 4

TRACK / STRECKE: Oswestry

AIR TEMP / UMGEBUNGSTEMP.: 25 °

TRACK SIZE / STRECKENGRÖSSE: Large

SURFACE / STRECKENBELAG: Worn Out Grass / Dirt

TRACTION LEVEL / GRIFF: Low

CONDITIONS / WETTER: Dry

RIDE HEIGHT
BODENFREIHEIT / GARDE AU SOL: 20 mm

CAMBER ANGLE
STURZ / ANGLE DE CARROSSAGE: -2 °

CASTOR ANGLE
NACHLAUF / ANGLE DE CHASSE: Kit °

TOE IN/OUT
VONSPUR/NACHSPUR / ANGLE DE PINCEMENT: +/- 0 °

DIFF. OIL
DIFF. ÖL / HUILE DE DIFF.: 5000 .wt

SWAY BAR
STABILISATOR / BARRE ANTI-ROULIS: None mm

SWAY BAR LINK
STABILISATOR HEBELLANGE / LIEN DE LA BARRE ANTI-ROULIS: mm

NOTES
NOTIZEN / REMARQUES:

FRONT VORN AVANT

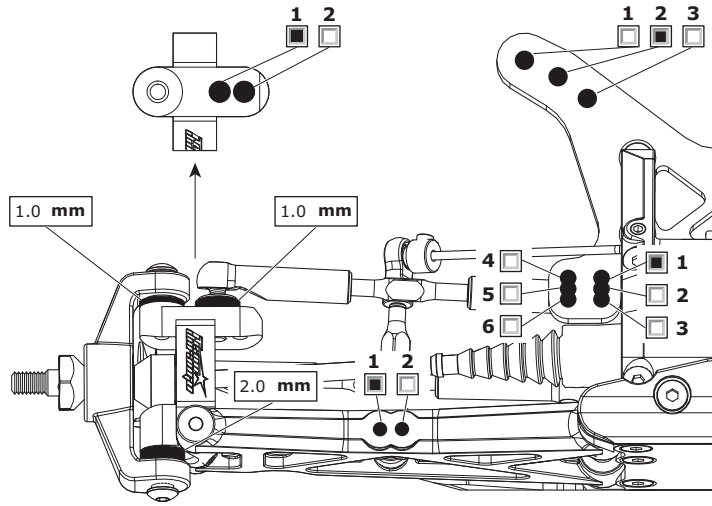

RIDE HEIGHT
BODENFREIHEIT / GARDE AU SOL: 20 mm

CAMBER ANGLE
STURZ / ANGLE DE CORROSSAGE: 1.5 °

DIFF. OIL
DIFF. ÖL / HUILE DE DIFF.: 7000 .wt

SWAY BAR
STABILISATOR / BARRE ANTI-ROULIS: None mm

SWAY BAR LINK
STABILISATOR HEBELLANGE / LIEN DE LA BARRE ANTI-ROULIS: None mm

WISHBONE DROOP
AUSFEDERWEG / DROOP DES TRIANGLES ARRIÈRES: Max With Screws mm

NOTES
NOTIZEN / REMARQUES:

REAR HINTEN ARRIÈRE

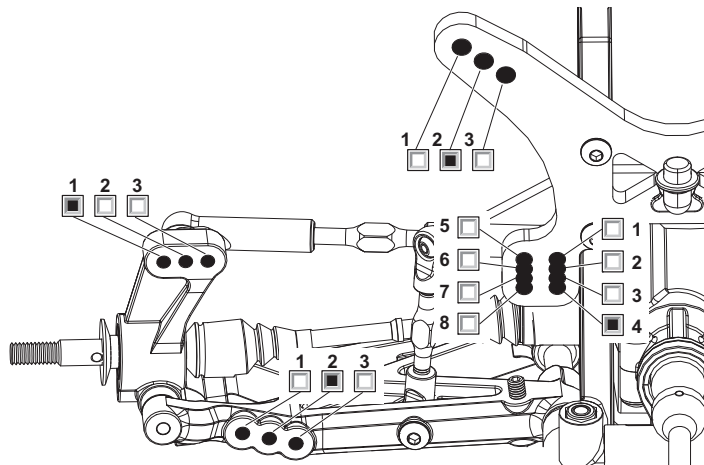

MOTOR
MOTOR / MOTEUR: SP v3.0 5.5T

SPUR GEAR
HAUPTZAHNRAD / COURONNE: 87

PINION GEAR
RITZEL / PIGNON: 22

BATTERY
AKKU / ACCUMULATEUR: Speed Passion 4200 30c

ESC SETTINGS
REGLER PROGRAMM / RÉGLAGE DU VARIATEUR: DDRS=7, Brake =100%

BALLAST POSITION
GEWICHTSPOSITION / POSITION DES LEST:
 SIDES SKIDPLATE

WING
FLÜGEL / TYPE D'AILERON: DEX410

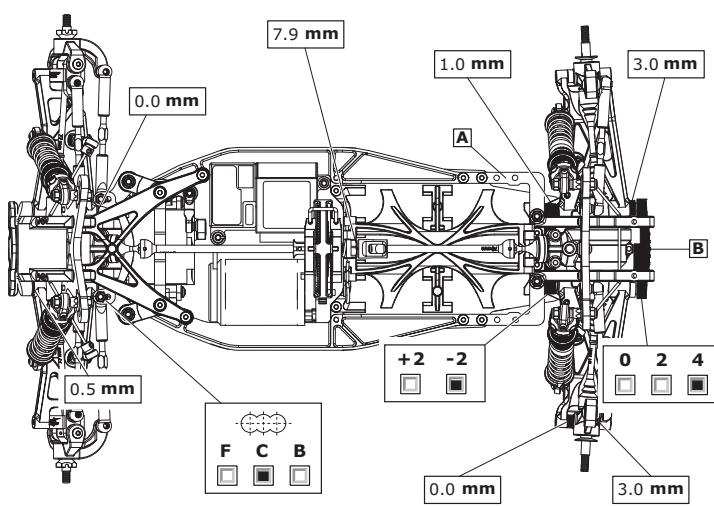

FRONT SHOCKS VORNE DÄMPFER AVANT AMORTISSEURS

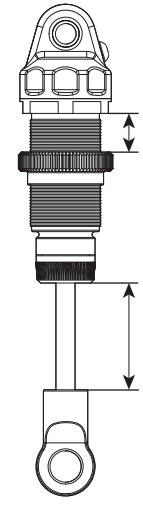

SPRINGS
FEDERN / RESSORTS: Dark Blue

REBOUND
REBOUND / REBOND: 0 %

PRELOAD
FEDERVORSpannung / PRÉCONTRAINTÉ: mm

OIL WT.
ÖLVISKOSITÄT / GRADE HUILE: 450 cST

PISTON
KOLBEN / PISTON: 2 x 1.3 GHEA

LENGTH
LÄNGE / LONGUEUR: 24.0 mm

NOTES
NOTIZEN / REMARQUES: 2mm Restrictor Inside Shock. Boots on.

REAR SHOCKS HINTEN DÄMPFER ARRIÈRE AMORTISSEURS

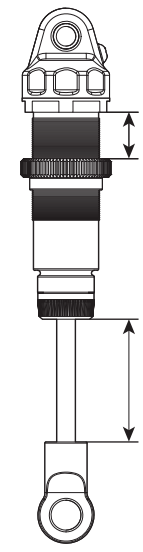

SPRINGS
FEDERN / RESSORTS: Light Green

REBOUND
REBOUND / REBOND: 0 %

PRELOAD
FEDERVORSpannung / PRÉCONTRAINTÉ: mm

OIL WT.
ÖLVISKOSITÄT / GRADE HUILE: 400 cST

PISTON
KOLBEN / PISTON: 3 x 1.4mm GHEA

LENGTH
LÄNGE / LONGUEUR: 33.5 mm

NOTES
NOTIZEN / REMARQUES: Boots On

TYRES REIFEN PNEUS

FRONT	REAR
BRAND / HERSTELLER / MARQUE: Schumacher M/Spike	Schumacher M/Spike
COMPOUND / MISCHUNG / COMPOUND: Yellow	Yellow
INSERT / EINLAGEN / INSERT: Edit Purple	Edit Purple
WHEEL / FELGE / JANTE: DEX410	DEX410
NOTES / NOTIZEN / REMARQUES: Rear: Outside Off. Front : Inside and Outside off. Every other one off 2nd outer row.	

RESULTS PLATZIERUNG RÉSULTAT
 QUALIFYING POSITION / VORLAUFERGBNIS / POSITION EN QUALIFICATION: 17th
 FINAL POSITION / ENDPLATZIERUNG / POSITION FINALE: 14th

AVERAGE LAP / DURCHSCHNITTSZEIT / TEMPS AU TOUR MOYEN: _____
BEST LAP / SCHNELLSTE-RUNDE / MEILLEUR TEMPS AU TOUR: _____
RACE TIME / RENWDAUER / DURÉE DE LA COURSE: _____

