

TEAM DURANGO DEX410 SETUP SHEET

PRINT

SUBMIT

NAME / NOM: Adam Skelding

DATE / DATUM: 12/06/2010

SETUP BLATT / FICHE DE RÉGLAGE V1.3 E

EVENT / VERANSTALTUNG: oOple Invernational

TRACK / STRECKE: RHR (Robin Hood Raceway)

AIR TEMP / UMGEBUNGSTEMP.: 20 °

TRACK SIZE / STRECKENGRÖSSE: Large

SURFACE / STRECKENBELAG: Astroturf

TRACTION LEVEL / GRIFF: High

CONDITIONS / WETTER: Dry/Damp

FRONT VORN AVANT

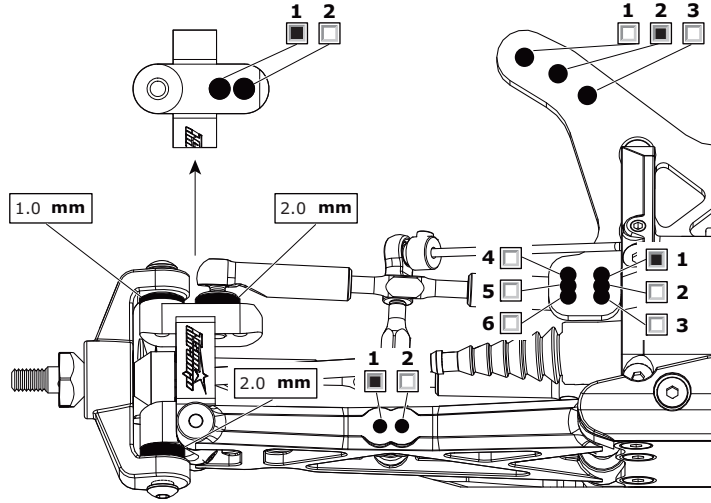

REAR HINTEN ARRIÈRE

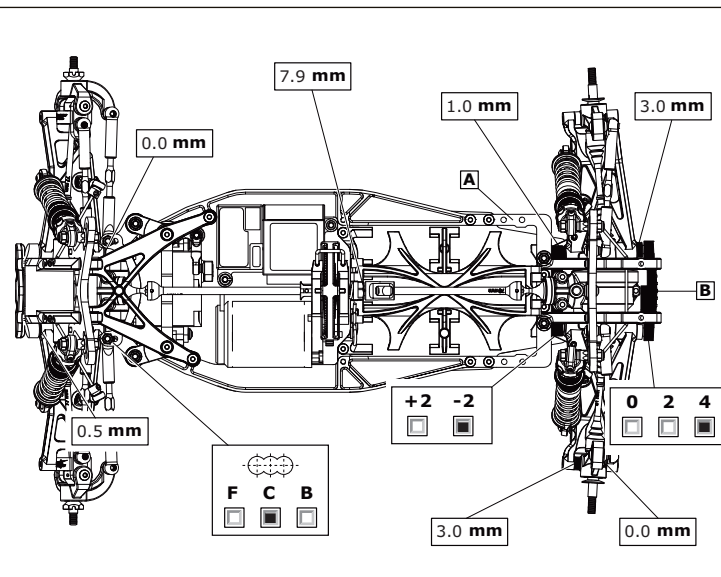
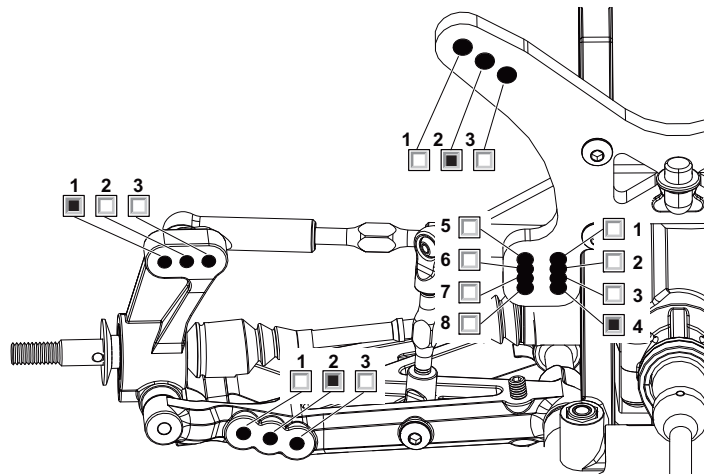

RIDE HEIGHT / BODENFREIHEIT / GARDE AU SOL: 20 mm

CAMBER ANGLE / STURZ / ANGLE DE CARROSSAGE: -1.5 °

CASTOR ANGLE / NACHLAUF / ANGLE DE CHASSE: Kit

TOE IN/OUT / VONSPUR/NACHSPUR / ANGLE DE PINCEMENT: +/- 0

DIFF. OIL / DIFF. ÖL / HUILE DE DIFF.: 5000 .wt

SWAY BAR / STABILISATOR / BARRE ANTI-ROULIS: None mm

SWAY BAR LINK / STABILISATOR HEBELLANGE / LIEN DE LA BARRE ANTI-ROULIS: mm

NOTES / NOTIZEN / REMARQUES: Yes 5000wt diff oil (5K)

RIDE HEIGHT / BODENFREIHEIT / GARDE AU SOL: 20 mm

CAMBER ANGLE / STURZ / ANGLE DE CORROSSAGE: -1.5 °

DIFF. OIL / DIFF. ÖL / HUILE DE DIFF.: 7500 .wt

SWAY BAR / STABILISATOR / BARRE ANTI-ROULIS: None mm

SWAY BAR LINK / STABILISATOR HEBELLANGE / LIEN DE LA BARRE ANTI-ROULIS: None mm

WISHBONE DROOP / AUSFEDERWEG / DROOP DES TRIANGLES ARRIÈRES: Max with screws mm

NOTES / NOTIZEN / REMARQUES: 6 minute Racing

MOTOR / MOTOR / MOTEUR: SPV3.0 5.5T

SPUR GEAR / HAUPTZAHNRAD / COURONNE: 87T

PINION GEAR / RITZEL / PIGNON: 22

BATTERY / AKKU / ACCUMULATEUR: SpeedPower 4200 30C

ESC SETTINGS / REGLER PROGRAMM / RÉGLAGE DU VARIATEUR: DDRS = 7, Brake = 100%

BALLAST POSITION / GEWICHTSPOSITION / POSITION DES LEST: SIDES SKIDPLATE

WING / FLÜGEL / TYPE D'AILERON: DEX410

FRONT SHOCKS / VORNE DÄMPFER / AVANT AMORTISSEURS

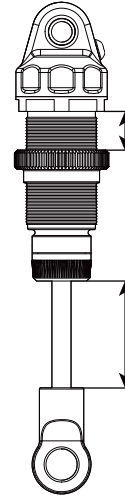

SPRINGS / FEDERN / RESSORTS: Dark Blue

REBOUND / REBOUND / REBOND: 0 %

PRELOAD / FEDERVORSpannung / PRÉCONTRAINTÉ: 9.0 mm

OIL WT. / ÖLVISKOSITÄT / GRADE HUILE: 450 cST

PISTON / KOLBEN / PISTON: 2 x 1.3mm GHEA

LENGTH / LÄNGE / LONGUEUR: 24.0 mm

NOTES / NOTIZEN / REMARQUES: 2mm Spacer inside shock.

REAR SHOCKS / HINTEN DÄMPFER / ARRIÈRE AMORTISSEURS

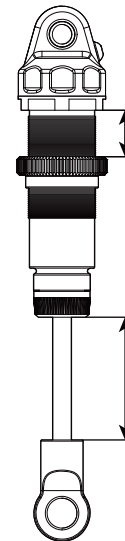

SPRINGS / FEDERN / RESSORTS: Light Blue

REBOUND / REBOUND / REBOND: 0 %

PRELOAD / FEDERVORSpannung / PRÉCONTRAINTÉ: 6.8 mm

OIL WT. / ÖLVISKOSITÄT / GRADE HUILE: 400 cST

PISTON / KOLBEN / PISTON: 3x1.4mm GHEA

LENGTH / LÄNGE / LONGUEUR: 33.5 mm

NOTES / NOTIZEN / REMARQUES:

TYRES REIFEN PNEUS

FRONT	REAR
BRAND / HERSTELLER / MARQUE: Ballistic Buggy Spike	BRAND / HERSTELLER / MARQUE: Ballistic Buggy Spike
COMPOUND / MISCHUNG / COMPOUND: Green	COMPOUND / MISCHUNG / COMPOUND: Green
INSERT / EINLAGEN / INSERT: KWF	INSERT / EINLAGEN / INSERT: KWF
WHEEL / FELGE / JANTE: DEX410	WHEEL / FELGE / JANTE: DEX410
NOTES / NOTIZEN / REMARQUES: Inside and outside off front. Full Rear tyres	

RESULTS / PLATZIERUNG / RÉSULTAT: QUALIFYING POSITION / VORLAUFERGESNIS / POSITION EN QUALIFICATION: 8th FINAL POSITION / ENDPATZIERUNG / POSITION FINALE: 8th

AVERAGE LAP / DURCHSCHNITZTZEIT / TEMPS AU TOUR MOYEN: 28.77 BEST LAP / SCHNELLSTE-RUNDE / MEILLEUR TEMPS AU TOUR: 28.01 RACE TIME / RENWDAUER / DURÉE DE LA COURSE: 13: 374.02